

Peat Biofilter

Wastewater Treatment Systems

Guidance Document

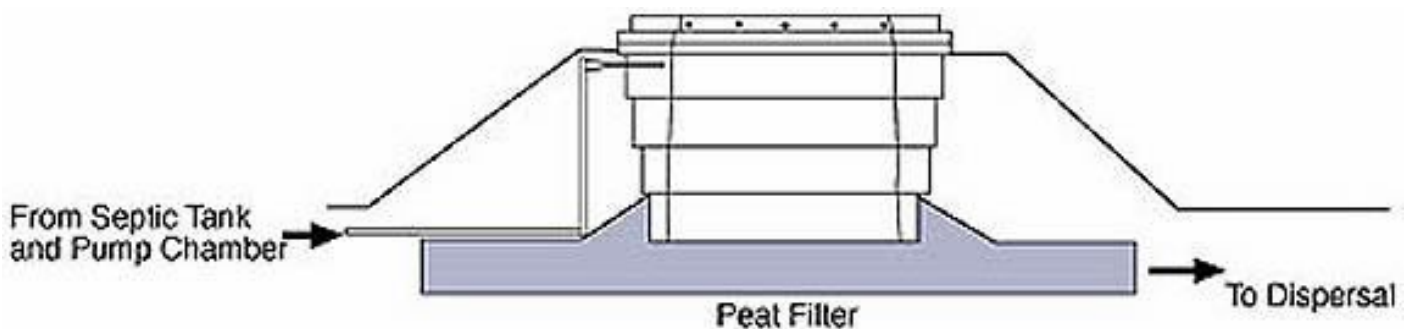

NEW JERSEY DEPARTMENT OF ENVIRONMENTAL PROTECTION
DIVISION OF WATER QUALITY
BUREAU OF NONPOINT POLLUTION CONTROL



JANUARY 2008

TABLE OF CONTENTS

A. PURPOSE	3
B. GENERAL CONDITIONS	3
C. PEAT BIOFILTER TREATMENT SYSTEM DESCRIPTION	4
D. EFFLUENT QUALITY	4
E. PEAT BIOFILTER TREATMENT SYSTEM DESIGN	4
F. DISPERSAL METHODS	6
G. DISPERSAL SYSTEM SITING & SIZING CRITERIA	6
H. PEAT BIOFILTER TREATMENT SYSTEM INSTALLATION	7
I. PEAT BIOFILTER TREATMENT SYSTEM START-UP	8
J. PEAT BIOFILTER TREATMENT SYSTEM OM&M	8
K. TRAINING & EDUCATION	9
L. REPORTING	10
M. MANUFACTURER RESPONSIBILITIES	10
N. PROPERTY OWNER RESPONSIBILITIES	11
O. ADMINISTRATIVE AUTHORITY RESPONSIBILITIES	12
APPENDIX A: DEFINITIONS	13

A. Purpose

This guidance document is limited in applicability to onsite wastewater treatment systems subject to regulation under N.J.A.C. 7:9A.

The use of a peat biofilter treatment system may be allowed, as described below, for new construction, expanded project or to alter an existing, malfunctioning system. Under these circumstances, a peat biofilter treatment system may be considered by the local administrative authority, at their discretion. The issuance of this guidance does not exempt the applicant or his agents from the responsibility to comply with all applicable Federal, State, County and Municipal rules and regulations.

Proposals for use of a peat biofilter treatment unit for a new or expanded project are allowed, provided the peat biofilter treatment system is in addition to and not in lieu of any part of a system that meets all of the requirements of N.J.A.C. 7:9A. All other proposals for use of this technology for a new or expanded system that differ from the requirements of N.J.A.C. 7:9A, including variations from the regulatory requirements discussed in this guidance, must be directed to the Department for an individual Treatment Works Approval (TWA). The application must demonstrate that the site can support an individual subsurface sewage disposal system, which meets strict conformance with the requirements of N.J.A.C. 7:9A, on the property. TWA's will contain requirements for the proper maintenance and management of these systems that must be performed by the system owner and enforced by the administrative authority.

In accordance with N.J.A.C. 7:9A-3.3, alterations to repair existing, malfunctioning systems may be made in a manner that is in more compliance with current standards than the malfunctioning system. The Department interprets that regulation to provide the local administrative authority with the ability to approve of alterations using advanced treatment technologies, including a peat biofilter treatment system, described herein. These guidelines may not be construed as a device to require the use of a technology in any jurisdiction, does not limit the local administrative authority's ability to have additional requirements in their approval, and does not limit the local administrative authority's ability to apply the technology in applications that do not strictly meet these guidelines. As stated in the guidelines for administrative authorities, below, any questions regarding variances from these guidelines should be conveyed by the affected local administrative authority directly to the Department.

B. General Conditions

1. The Department may revise these guidelines or discontinue the use of any peat biofilter treatment systems at any time.
2. The Department will maintain a list of applicable manufacturers that have agreed to the provisions of this guidance and have demonstrated the ability to comply with the conditions of the guidance.
3. Any peat biofilter treatment system manufacturer that wishes to be listed as applicable under this guidance document shall submit a written request, a copy of their NSF Standard 40, ETV or other verification report and a report to the Department that details how the manufacturer will achieve compliance with the appropriate portions of this guidance document.
4. Any peat biofilter treatment system manufacturer that fails to comply with the provisions of this or any applicable document will be removed from the applicability list subject to this guidance. The Department will advise any affected manufacturer prior to taking this action.

5. For the life of the system, the owner of the system must have in place a preventative maintenance and monitoring contract with an Authorized Service Provider to ensure it is functioning properly and to optimize treatment performance. As part of this contract, the Authorized Service Provider must conduct a visual inspection of the internal components, including any treatment media, and maintain the complete treatment system. Upon expiration of a maintenance and monitoring contract, a new contract, which shall be at least one year in duration, shall be entered into by the property owner with an Authorized Service Provider. If the property owner fails to renew the maintenance and monitoring contract, written notification of such must be directed, by the Authorized Service Provider, to the local administrative authority.

C. Peat Biofilter Treatment System Description

Peat biofilter treatment units use sphagnum peat moss or peat fiber for removing and retaining contaminants until they are broken down. The partially treated septic tank effluent is dosed several times a day or conveyed by gravity to the peat module units. As the wastewater percolates through the peat medium, it is absorbed briefly where beneficial aerobic microorganisms degrade the waste constituents. Peat provides a large surface area as well as void space for air movement to put oxygen in contact with the thin films of wastewater moving over the peat medium. For final effluent disposal, the peat biofilter treatment system can employ an open-bottom design that is installed over a gravel bed, or a closed-bottom design that discharges to a conventional disposal area or drip dispersal.

D. Effluent Quality

Because of the significant reduction in biological oxygen demand and total suspended solids that occurs in a peat biofilter treatment system, the soil is relied upon more for dispersal capabilities rather than treatment of effluent. The reduced organic concentration in the treated effluent allows for a smaller sized dispersal system to be relied upon to accomplish hydraulic dispersal of the treated effluent.

E. Peat Biofilter Treatment System Design

1. All system designs must be signed and sealed by a New Jersey licensed professional engineer (N.J.P.E.). The N.J.P.E. must be trained and authorized by the manufacturer as an Authorized Designer to design peat biofilter treatment systems.
2. No peat biofilter treatment system shall be designed in a manner which does not meet the manufacturer's minimum recommendations.
3. If the estimated volume of sanitary sewage for the structure(s) served, as calculated using N.J.A.C. 7:9A-7.4, is greater than the manufacturer's specifications for maximum flow to the proposed peat biofilter treatment unit, the manufacturer's sizing criteria may be used for sizing the treatment unit only.
4. Peat biofilter treatment units may only be installed within saturated, subsurface conditions (including, but not limited to seasonal high water tables) if the treatment unit enclosure is a single piece unit and can be demonstrated to be water tight. All peat biofilter treatment units that will be located within a saturated soil condition must be designed in a manner that considers all structural issues including, but not limited to, buoyancy and structural effects on the treatment unit

5. Any Authorized Designer that submits a peat biofilter treatment system design to any local administrative authority must notify the Department in writing or by email at CH199@dep.state.nj.us within 24 hours of the submittal to the local administrative authority.
6. Treatment System Design Review
 - a. Residential Systems: Prior to issuing a construction approval, the local administrative authority may require plans to be reviewed by the technology manufacturer or the manufacturer's authorized representative to determine consistency with manufacturer's minimum specifications and recommendations for achieving treatment.
 - b. Commercial Systems: Prior to submitting the treatment system design for construction approval, the peat biofilter treatment system design shall be reviewed by the manufacturer. The manufacturer shall issue a letter to the designer indicating the design is consistent with manufacturer's minimum specifications and recommendations for achieving treatment.
7. All peat biofilter treatment systems may be equipped with a telemetry control panel which is attached to an internet based interface that provides continuous remote monitoring, information management and control of each individual aerobic treatment system. Sites that do not have a telemetry control panel must use an active phone line equipped with an auto dialer to notify the authorized service provider of alarm conditions, including if power to any of the system equipment is disconnected. The system should also include a control panel that tracks, at minimum, pump elapsed time, cycle counts and high level alarm counts or other means to determine flow through the system and other system information for troubleshooting purposes, as recommended by the manufacturer. This condition is not required for any system that contains no electrical components, such as a pump or a blower.
8. The peat biofilter treatment unit(s) must maintain the same setbacks as required for septic tanks at N.J.A.C. 7:9A-4.3.
9. In cases where setbacks to wells can not be increased to meet current requirements, the local administrative authority should consider ultraviolet disinfection on the well in addition to, or instead of, disinfection of the wastewater in accordance with G.8., below.
10. Alterations to systems which serve a structure containing a garbage grinder unit should require full compliance with N.J.A.C. 7:9A-1 et seq. When the use of a garbage grinder or grinding sewage ejector pump is required, the minimum liquid capacity of the septic tank should be at least 1500 gallons or meet the requirements of N.J.A.C. 7:9A-8.2(c), whichever is greater. The area required for disposal area sizing shall be increased by 50% prior to the application of any allowable reduction in disposal area.
11. Systems incorporating peat biofilters shall include an effluent filter in the design.
12. Open bottom dispersal designs shall incorporate inspection ports in each corner of the dispersal area to the level of infiltration. A deep inspection port to the depth of the full excavation may be incorporated into the design or required by the local administrative authority.

F. Dispersal Methods

Treated effluent from the peat biofilter treatment system shall be dispersed into the ground by any of the following methods:

1. Any New Jersey disposal field as allowed in N.J.A.C. 7:9A and sized according to those Standards or this guidance document.
2. Seepage pits as allowed by N.J.A.C. 7:9A.
3. Drip dispersal systems as outlined in the Department's Drip Dispersal Wastewater Disposal Systems Guidance Document.
4. Open bottom peat biofilter designs if allowed by the manufacturer. Open bottom disposal mechanisms may be allowed by a local administrative authority, at their discretion, without the use of a conventional disposal field. Sizing for these designs are provided in these guidelines. Care should be taken using open bottom disposal designs in native soils with permeability less than 2 inches per hour. When other limiting zones are present in these soils, the potential for breakout must be considered and evaluated in the design.

G. Dispersal System Siting & Sizing Criteria

1. Permeability testing to determine the size of a dispersal area should be completed in native soils. For soil replacement systems, design permeability shall be determined after delineating an adequate zone of disposal as required in N.J.A.C. 7:9A-10.1(e). When the permeability in the zone of disposal has been determined to be greater than 0.2 inches per hour using test options 1, 5 or 6 (Table 6.1, below) or test option 4 where the basin drains in three hours or less, the permeability of the fill material shall be used. When other tests are used and are not verified by test options 1, 5 or 6, the soil horizon of slowest permeability within the proposed adequate zone of disposal shall be used. If a passing basin flooding test takes three or more hours to drain after any filling, the design permeability range of 0.2-0.6 inches per hour shall be used.
2. The peat biofilter unit is an extension of the zone of treatment. An adequate zone of treatment must be accounted for in the design of all peat biofilter systems. In addition to the peat biofilter, an additional 18 inches, minimum, of suitable soil or select fill material, if necessary, shall be located beneath an open bottom or N.J.A.C. 7:9A disposal area design. This additional zone of treatment does not have to be continuous, but must be entirely above the seasonal high water table. Gravel material shall not be included in the zone of treatment.
3. A peat biofilter unit that is enclosed in a water tight vessel may be located within a seasonal high water table or other saturated soil condition if that unit is installed in accordance with the manufacturer's specifications for installation under those conditions. If the vessel is installed within a saturated soil condition, the vessel shall be tested for water tightness following the installation of that vessel. Water tightness testing shall be conducted in a manner that includes all risers and joints (i.e., top of the tank or highest seam in the riser), and shall be certified by a New Jersey Licensed Professional Engineer.
4. An acceptable zone of disposal, not including the gravel zone, should be demonstrated to be present in compliance with N.J.A.C. 7:9A-10. Gravel may not be used in lieu of select fill beneath the bottom of the zone of treatment. This condition shall not be applied to drip dispersal designs.

5. If a drip dispersal system is used, it shall be sized according to the appropriate guidance document.
6. For systems located in areas where the depth to the seasonal high water table will be present at a depth more shallow than 24 inches of the bottom of a dispersal system or where the existing, malfunctioning system infringes upon a horizontal setback to a well and the new system will not fully meet current setback requirements, ultraviolet (UV) disinfection of the wastewater may be required immediately prior to dispersal in the design of the system. However, additional filtration to reduce turbidity may also be required to allow for UV disinfection to work properly. It is the responsibility of the system designer to design and ensure the installation a UV disinfection system that is designed to achieve fecal coliform levels of 200 colonies per 100 ml or less, based upon anticipated effluent quality at the point of disinfection. Any disinfection equipment shall be covered by the same warranty, maintenance and inspection conditions specified in this document.
7. Conventional disposal beds and open bottom designs may be sized according to the following chart:

					Minimum Bed Size (sq.ft.)			
Soil Class	Permeability (in/hr)	Percolation Rate (min/in)	Standard A/Q (sqft/gpd)	Adjusted A/Q (sqft/gpd)	350gpd/2BDRM	500gpd/3BDRM	650gpd/4BDRM	800gpd/5BDRM
K4	6-20	3-15	1.61	1.233	432	617	802	987
K3	2-6	16-30	2.08	1.704	597	853	1,108	1,364
K2	0.6-2	31-45	2.56	2.190	767	1,095	1,424	1,752
K1	0.2-0.6	46-60	2.96	2.596	909	1,298	1,688	2,077
Pressure Dosing Design			1.33	0.956	400*	479	622	765

* The Department does not recommend sizing disposal beds at less than 400 sq.ft.

8. For the alteration of a malfunctioning system where native soil percolation rates are between 60 and 120 minutes per inch, a peat biofilter treatment system may be used in conjunction with a conventional disposal field if drip dispersal is not feasible, however the design engineer must provide a detailed analysis of the proposed disposal field to identify that the sizing criteria chosen is appropriate and adequate for the alteration.

H. Peat Biofilter Treatment System Installation

1. A preconstruction conference is highly recommended prior to beginning construction of the system and should be attended by the Authorized Designer of the system, the Authorized Installer, and the local administrative authority.
2. All peat biofilter treatment systems shall be installed according to directions provided in each peat biofilter manufacturer's installation manual and approved peat biofilter treatment system design.
3. All companies/personnel installing a peat biofilter treatment system shall be in possession of all necessary permits and licenses before attempting any portion of an installation.
4. Only an Authorized Installer shall install a peat biofilter treatment system.

5. The Authorized Installer must notify the Department at least one week prior to the installation of the peat biofilter units at CH199@dep.state.nj.us and coordinate inspections with the Department in addition to any inspections required by the local administrative authority.
6. An Authorized Installer must be present at all times during peat biofilter treatment system installation. No work on a peat biofilter treatment system may be conducted unless under the direct supervision of an Authorized Installer.
7. Watertightness of any septic, processing and dispersal system dosing tanks specified in the design must be watertight tested at the installation site after being installed using hydrostatic or vacuum tests. Testing of the tanks shall include all upper portions of the tank, including riser joints. Testing must be done in accordance with the following:
 - a. Water tightness testing procedures and criteria for concrete tanks shall follow the methods described in ASTM C-1227 standards or National Precast Concrete Association appropriate testing criteria and procedures
 - b. Tanks made of materials other than concrete shall be tested, after installation, in accordance with the methods described in ASTM C-1227 standards, if applicable, or other hydrostatic or vacuum testing methods approved by the tank manufacturer.
 - c. Water used for this testing shall be either from a potable water source or Reclaimed Water for Beneficial Reuse authorized by a NJPDES permit.
 - d. The use of an onsite potable well for purposes of supplying water for this testing is not recommended. If an onsite potable well is to be used, pumping of the well must be done in a manner which will withdraw water at a rate less than 50% of the safe yield of that well and will not damage the pump or any other component of the well.

I. Peat Biofilter Treatment System Start-up

1. The Authorized Service Provider shall inspect the system following each installation. The Authorized Service Provider shall complete the System Start-up Checklist - contact the Manufacturer for a copy of the most recent edition of this checklist. The service provider shall provide the completed start-up checklist to the local administrative authority.
2. The Authorized Installer shall be present at the time of start-up.

J. Peat Biofilter Treatment System Operation, Maintenance & Monitoring

1. All peat biofilter treatment systems shall be maintained according to the peat biofilter manufacturer's Operation and Maintenance Manual by an Authorized Service Provider. An up to date copy of the manual must be made available upon request or on the manufacturer's website.
2. Peat biofilter treatment systems shall be inspected by an Authorized Service Provider on the following schedule, at a minimum:

- a. Once within 30 days following system startup.
 - b. Twice per year for the first year of system operation (excluding a., above); twice per year thereafter.
 - c. For all systems, a meeting with a new operator of the system is recommended at the time of transfer of the property. The local administrative authority should be notified of this meeting and invited to participate.
 - d. Additionally, as required by the manufacturer.
3. At each regularly scheduled maintenance visit, as outlined in the Operation and Maintenance Manual, the Authorized Service Provider shall, at minimum, observe, monitor and record:
 - a. Wastewater level in the tanks,
 - b. Any effluent/pump filter for clogging,
 - c. Clarity in NTU's
 - d. Final effluent for odor
 - e. All tanks for oily film
 - f. All tanks for foam
 - g. pH of final effluent
 - h. Ponding of effluent around a peat biofilter treatment system or dispersal area
 - i. For pump systems, all meter readings from the control panel.
 4. At least once per year the Authorized Service Provider shall, at minimum:
 - a. Measure sludge and scum levels in the septic tank and notify the homeowner if the tank is in need of pumping
 - b. Check effluent filter for clogging and clean, as needed.
 5. All peat biofilter treatment systems require an operation and maintenance contract to be in place with an Authorized Service Provider for the life of the system.
 6. All sites shall be tracked using, a web based program used to track and update site and system information, manage contact information, manage maintenance activities, and generate reports.
 7. Authorized Service Providers shall be trained and authorized by the manufacturer or the manufacturer's Authorized Dealer. An up to date list of Authorized Service Providers shall be made available upon request or on the manufacturer's website.
 8. The operation and maintenance contract must be signed by the property owner and an Authorized Service Provider prior to issuance of the occupancy permit.
 9. The Authorized Service Provider must have proper equipment and training to access and program any system control panel on site.

K. Training & Education

1. The manufacturer or authorized representative shall hold, at minimum, one training event annually for Designers, Service Providers, and Installers.
2. The manufacturer or authorized representative shall provide a written and dated authorization for Designers, Service Providers and Installers. This authorization shall be valid for one year for those who have completed the appropriate requirements.

3. A list of these authorized Designers, Service Providers, and Installers shall be kept up-to-date by the manufacturer and made available upon request or on the manufacturer's website.
4. The manufacturer shall hold free training when necessary for New Jersey regulators that covers the design, installation and service of a peat biofilter treatment system.
5. All Authorized Designers, Service Providers and Installers shall be required to receive annual, or more frequently as needed, refresher training as a requirement to continue to be authorized by the manufacturer. An updated system integrator authorization shall be provided after refresher training has been successfully attended.

L. Reporting

1. The manufacturer or authorized representative shall submit an annual report to NJ DEP by March 1st of each year containing the following information for the previous 12 months:
 - a. Number of peat biofilter treatment systems installed
 - b. The address of each installed peat biofilter treatment system, the owners name and address, the type of use (e.g. residential, commercial)
 - c. Date when a peat biofilter treatment system was installed and started up
 - d. Administrative authority and permit number
 - e. Status of the maintenance and monitoring contract
 - f. Number of inspection/maintenance calls conducted
 - g. The inspection results recorded on a Department approved inspection form and/or checklist, copies of which shall be made available by the peat biofilter manufacturer. The forms must be completed by a peat biofilter treatment system service provider and submitted to the Department upon written request.
 - h. General summary of the results for the year, all known problems or failures with a brief summary of the cause and remedial measures taken.
 - i. Any recommended changes to the design, installation and/or operation and maintenance procedures and a schedule for implementing those changes.
2. Web access to online information regarding the systems may be considered by the local administrative authority as an alternative or in addition to paper reporting.
3. Failure of a client to renew a service agreement shall be reported to the Department and local administrative authority within 30 days by the Authorized Service Provider.
4. The manufacturer or authorized representative shall submit to the Department a summary of any changes made to their design, installation or service documents within seven (7) business days of those changes. Design, installation or service documents shall be submitted to the Department upon request.

M. Manufacturer Responsibilities

1. All sites shall be tracked by the manufacturer or their designated authorized representatives to update site and system information, manage contact information, manage maintenance activities, and generate reports.
2. All components of the peat biofilter treatment system supplied by the peat biofilter manufacturer shall be covered under a minimum five-year warranty. This warranty shall be fully transferable to assure the current

homeowner that any equipment failure will be covered as stipulated in that warranty during the warranty period. This is provided that operation and maintenance of the treatment system is done in conformance with manufacturer's requirements as stipulated in that warranty. Additionally, any component of the system which is specifically identified by the peat biofilter treatment unit manufacturer, by manufacturer and model, shall be reviewed by the peat biofilter treatment system manufacturer to ensure that the required component is covered by a minimum five year warranty from the applicable manufacturer. This warranty provision should not be applied to components that are reviewed for acceptability for use in the manufacturer's systems, but are not specifically required (e.g., a list of tank manufacturer's and their tanks sizes which are acceptable for use with a particular peat biofilter treatment system).

3. Provide the property owner with a copy of this guidance document, the operation, maintenance and monitoring agreement and obtain their written acknowledgement of the need to comply with the provisions of this document via signature prior to the sale of any peat biofilter treatment system.
4. Institute and maintain a training program for prospective designers, installers, and service providers in the proper design, installation, and servicing of their system.
5. Maintain up to date lists of manufacturer Authorized Designers, Authorized Installers and Authorized Service Providers that have passed the training program and make these lists available upon request or on the manufacturer's website.
6. Maintain an up-to-date website that contains the information necessary to obtain all applicable Design, Installation, Start-up, Operation and Maintenance or other required documentation.
7. Establish a process for investigating complaints and removing authorized personnel from authorized lists as appropriate.
8. Provide the Department or any local administrative authority with all training materials and the expected qualifications for the installer and service providers upon request. The Department should be notified of any training event at least two weeks prior to the event. No administrative authority shall approve a peat biofilter treatment system without receiving all training and materials that are requested from the manufacturer.

N. Property Owner Responsibilities

1. The local administrative authority may require the property owner to record with the deed to the property a notice that identifies the technology, acknowledges the owner's responsibility to have in place at all times a maintenance and monitoring contract, and grants access to the property for the purpose of system monitoring, inspection and maintenance.
2. Have in place, at all times, an operation, maintenance and monitoring agreement with an Authorized Service Provider. Failure to maintain this agreement threatens and endangers human health and the environment by not providing an adequately operated and maintained system and shall constitute a public health nuisance violation and a violation of N.J.A.C. 7:9A-3.2 and/or 3.3(e), as applicable.
3. In accordance with applicable law, the Department and the local administrative authority may require the owner of the system to cease use of the system and/or to take any other actions as it deems necessary to protect public health, safety, welfare or the environment.

4. The peat biofilter treatment system may be approved for use in conjunction with the treatment and dispersal of sanitary sewage only. Non-sanitary sewage generated or used at the facility shall not be introduced into the system and shall be lawfully disposed of.
5. Provide any future purchaser of the property with a copy of this guidance, the operation, maintenance and monitoring agreement, any deed notices required by the local administrative authority for the property and obtain their approval via signature prior to entering into a contract of sale for the subject property.

O. Administrative Authority Responsibilities

1. The Department recommends that the local municipality in which the peat biofilter treatment system is proposed adopt a local ordinance authorizing the use of this technology. At a minimum, this ordinance should include monitoring and enforcement provisions to ensure that annual service agreements are maintained for the life of the system and appropriate fees to allow the local administrative authority to implement a tracking program. Establishment of a septic management program will be required for Treatment Works Approvals authorizing new construction or expansion applications using a peat biofilter treatment system.
2. Track, in database format, all approvals issued under this guidance. The information recorded shall include, at a minimum:
 - a. municipal block and lot information,
 - b. street address,
 - c. date of installation,
 - d. date of system start-up,
 - e. type of dispersal area,
 - f. the number of bedrooms at the facility, and
 - g. the type of dispersal area and size in square feet and the reduction allowed for the dispersal system,
 - h. the type of peat biofilter treatment systems used, and
 - i. identification of a peat biofilter treatment system designer and installer.
3. Contact the Department directly with any questions regarding the application of a peat biofilter treatment system application which include variances from this guidance or to discuss issues not addressed by this guidance. In no instance should any other party seek alternative guidance for a site specific system from the Department until the local administrative authority has expressed its position directly to the Department.
4. Identify in the construction approval for this system that the New Jersey Department of Environmental Protection must be notified at least one week prior to the installation of any component of the proposed system and the anticipated date of installing the peat biofilter treatment unit(s).
5. Identify in the construction approval for this system that failure to operate and maintain the system in accordance with the requirements outlined in this document and failure to maintain an agreement with an authorized service provider threatens and endangers human health and the environment by not providing an adequately operated and maintained system and shall constitute a public health nuisance violation and a violation of N.J.A.C. 7:9A-3.2 and/or 3.3(e).

Appendix A: Definitions

Authorized Designer: A licensed New Jersey Professional Engineer who has completed all manufacturer training requirements, including annual refresher training, and has been identified as "authorized" by the Manufacturer to design peat biofilter treatment systems.

Authorized Installer: An individual person who has completed all manufacturer training requirements, including annual refresher training, and has been identified as "authorized" by the manufacturer to install peat biofilter treatment systems.

Authorized Service Provider: An individual person who has completed all manufacturer training requirements, including annual refresher training, and has been identified as "authorized" by the manufacturer to service peat biofilter treatment systems.

Authorized Dealer: Company(s) who has been "authorized" by the manufacturer to distribute peat biofilter treatment system components. Contact the manufacturer to obtain information on their authorized dealers.

Department: New Jersey Department of Environmental Protection

Disposal Field: defined by N.J.A.C. 7:9A-2.1

Drip Dispersal System: A drip dispersal wastewater disposal system with associated tanks, pumps, control panels, and piping that is designed, installed, operated and maintained in accordance with the Department's Drip Dispersal Wastewater Disposal System Guidance.

Manufacturer: Company who directly manufactures components of a peat biofilter treatment system and holds proprietary rights to a peat biofilter treatment unit. For the purposes of this document the applicable Manufacturer's are listed by the Department in a separate document available on the Department's website or by request at CH199@dep.state.nj.us.

NTU: Nephelometric Turbidity Units. Measure of clarity

Peat biofilter treatment system: means a wastewater treatment device consisting of a peat biofilter treatment unit and associated pumps, piping and control panels which are part of an onsite wastewater treatment system.

System: An onsite wastewater treatment system regulated pursuant to N.J.A.C. 7:9A-1 et seq. For the purpose of this document the "System" is a peat biofilter treatment system with associated tanks, effluent distribution network, control panels and a disposal field or drip dispersal system.